

변경 사항			
기호	변경 내용	날짜	수정 승인

Vertical (수직형) Type

< 5- Port Rotary Joint >

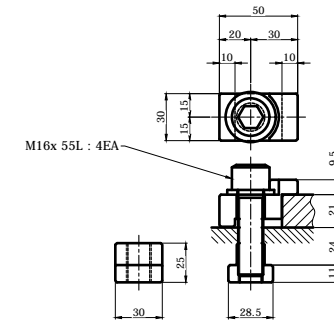
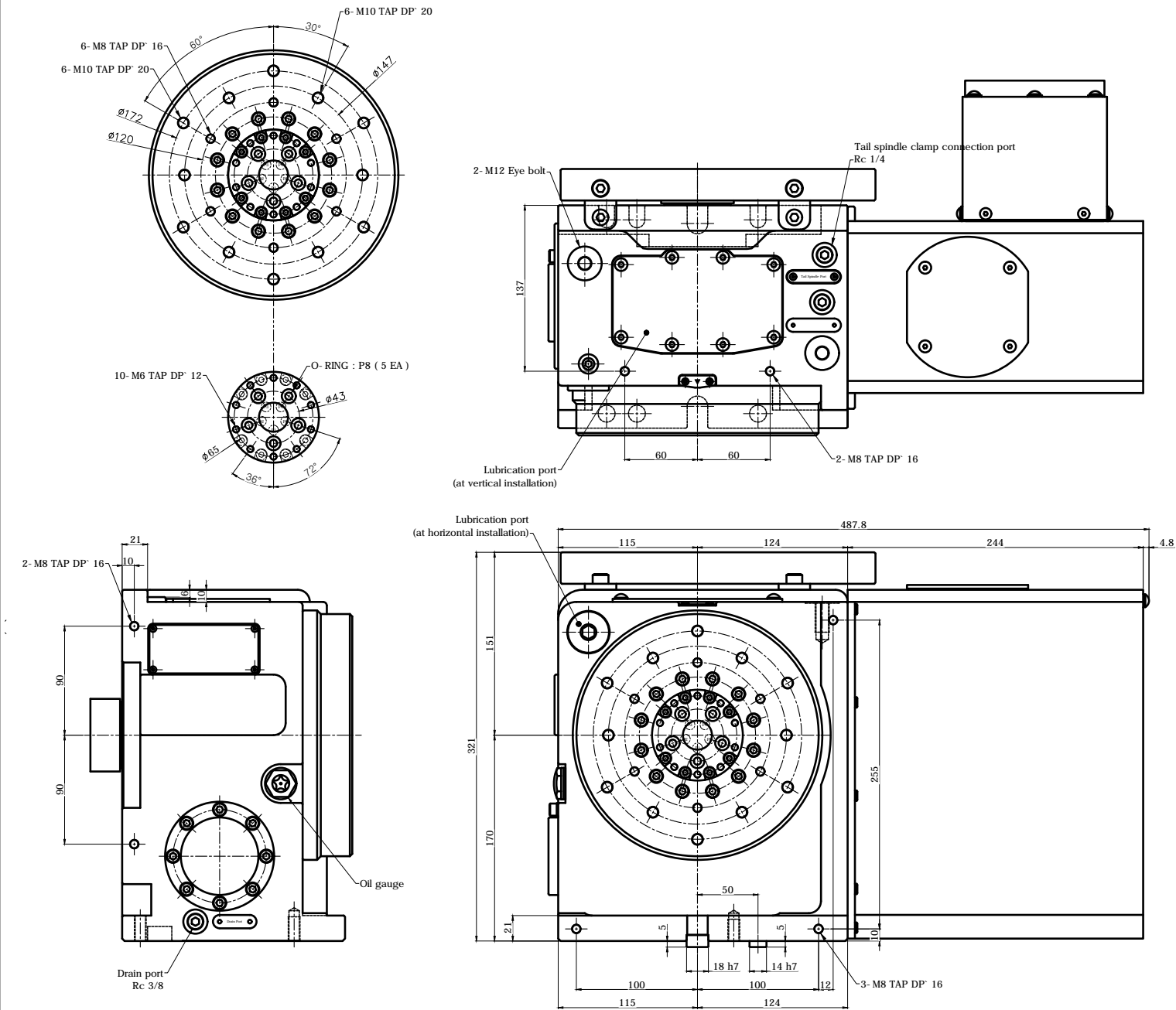

CLAMPING PARTS ACCESSORY 4 PAIR

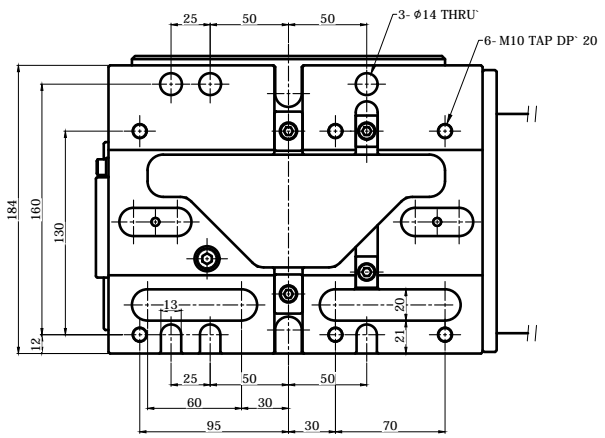
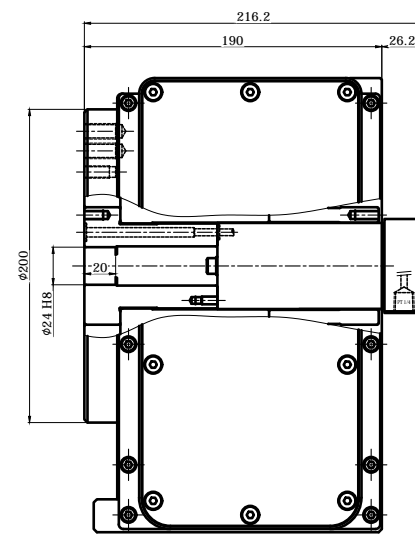
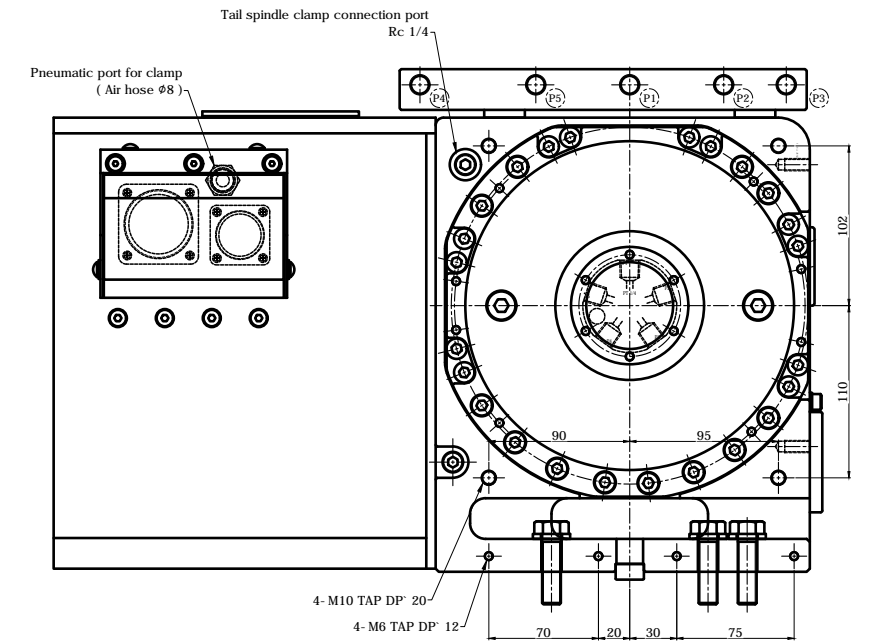
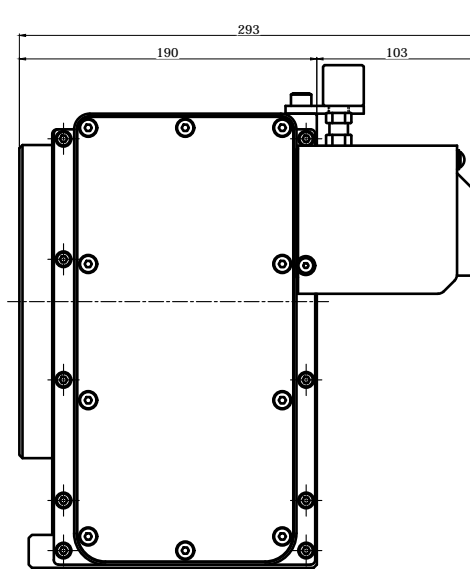

SPECIFICATION	
테이블 직경 Table Diameter	Ø200 mm
센터 높이 Center Height	170 mm
기준경 Reference Diameter	Ø24 H8
스핀들 통과 홀 직경 Spindle Through Hole Diameter	Ø24 H8
클램프 방식 Clamp Method	Pneumatic 5 ~ 7 kgf/cm ²
허용 모멘트 Allowable Work Inertia	0.5 kg·m ²
클램프 토크 Clamp Torque	310 N·m
최대 회전 속도 Max. Spindle Speed	50 min ⁻¹ (INVERTER WITH 2000 rpm ⁻¹)
기어비 Gear Ratio	1 / 50
무게 Weight	85 kg
기어 오일 Gear Lubrication	ISO VG #150
허용 하중 ALLOWABLE MASS OF WORK	100 kg [VER.]

[Rotary Joint Specifications]	
Temperature	MAX. 80°C
Hydraulic	MAX. 150 kgf/cm ²
RPM	MAX. 100 RPM
PORT	5 PORT

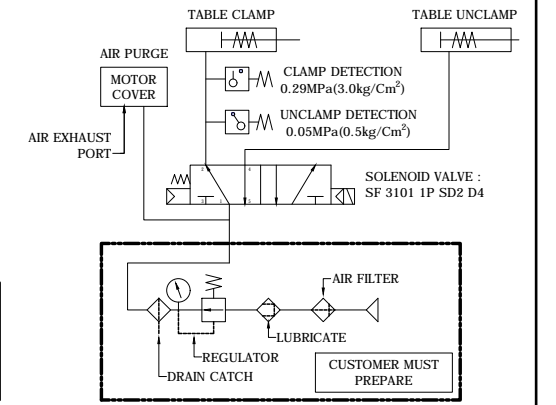

TITLE	Nc Rotary Table	PART NAME	요 형 도
DRG. NO.	RF-200F4 - Rotary Joint	USER	-
CODE NO.		DEPARTMENT	Research & Development
		DATE	2020.09.01
SCALE	1 : 1	Approved	Checked
		Designed	



변경 사항			
기호	변경 내용	날짜	수정 승인

Vertical (수직형) Type

< Rotary Joint 미 적용 >

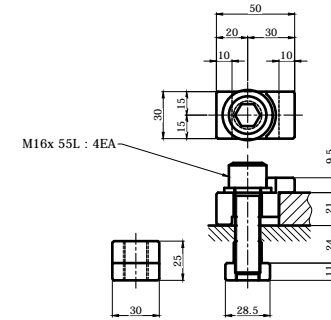
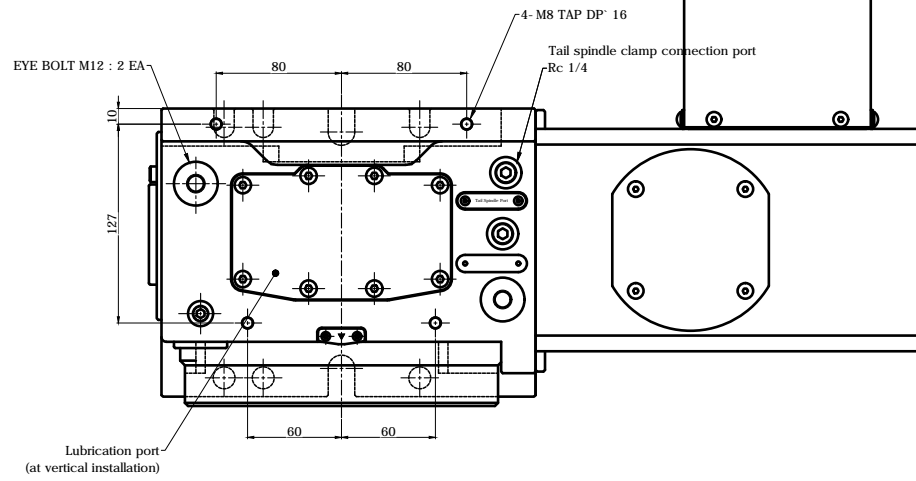
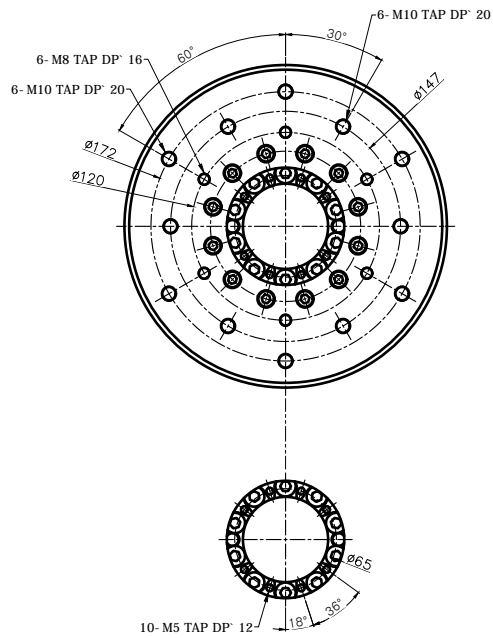

CLAMPING PARTS ACCESSORY 4 PAIR

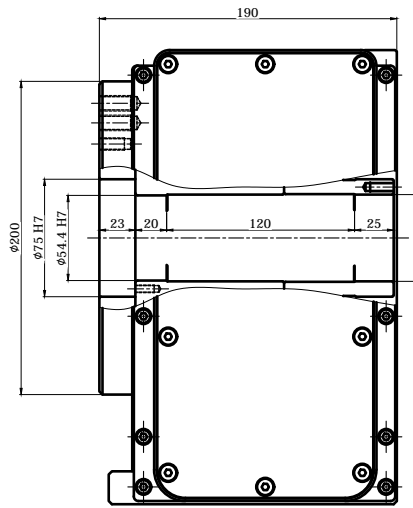
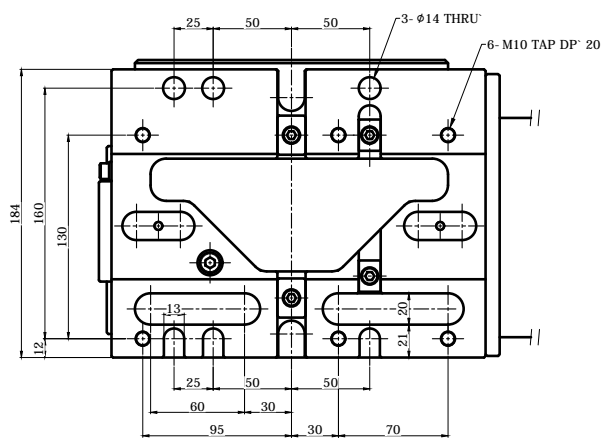
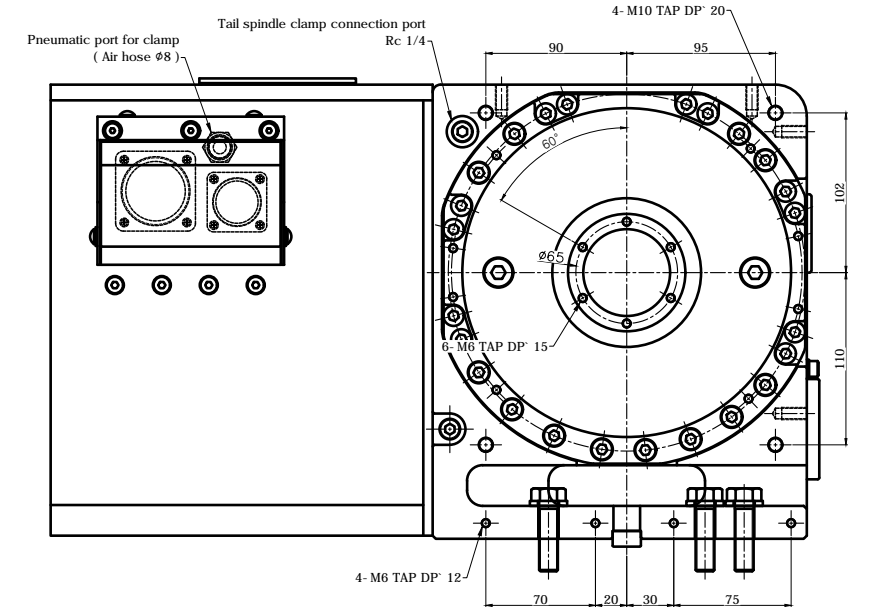
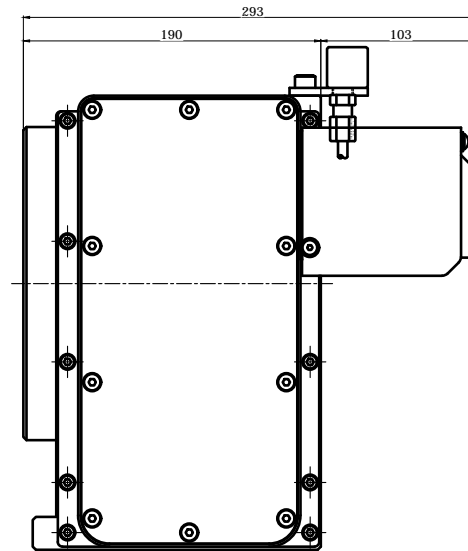
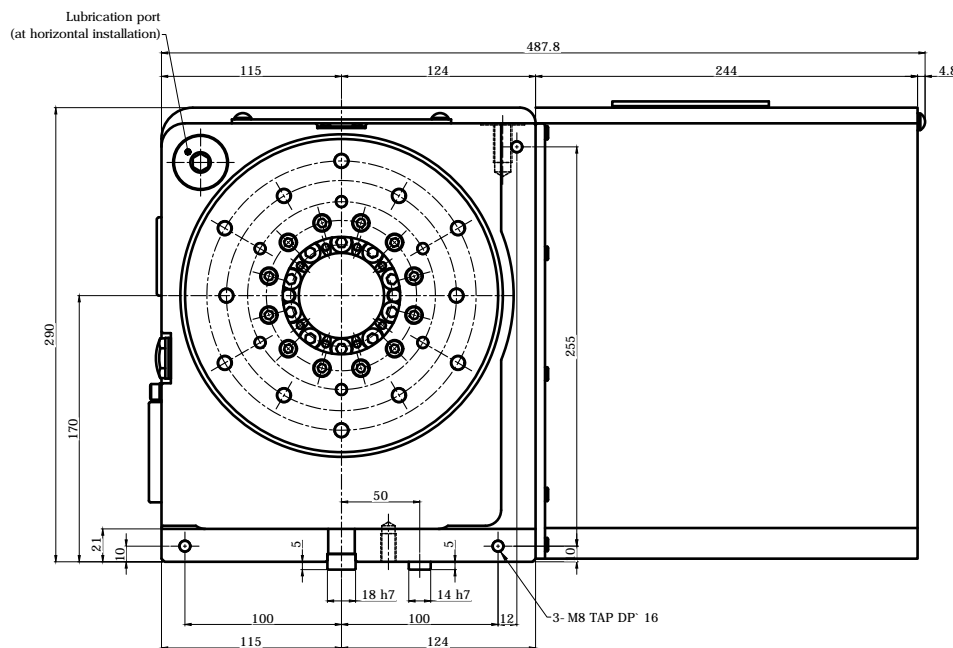
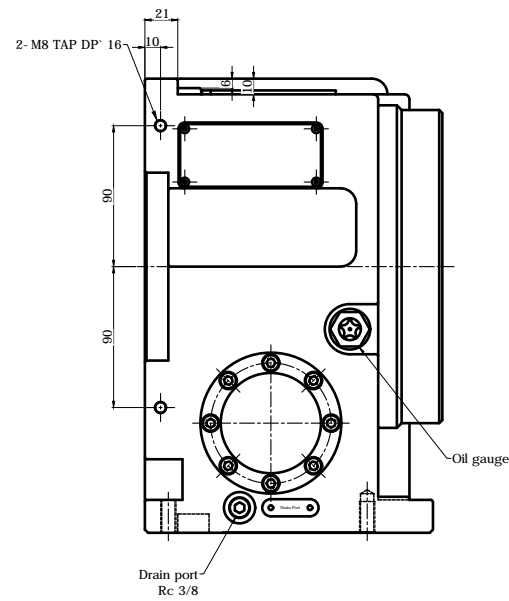

SPECIFICATION	
테이블 직경 Table Diameter	Ø200 mm
센터 높이 Center Height	170 mm
테이블 내경 Table Inner Diameter	Ø75 H7
관통경 Spindle Through Hole Diameter	Ø54.4 H7
클램프 방식 Clamp Method	Pneumatic 5 ~ 7 kgf/cm ²
허용 모멘트 Allowable Work Inertia	0.5 kg·m ²
클램프 토크 Clamp Torque	310 N·m
최대 회전 속도 Max. Spindle Speed	50 min ⁻¹ (INVERTER WITH 2000 rpm ⁻¹)
기어비 Gear Ratio	1 / 50
무게 Weight	82 kg
기어 오일 Gear Lubrication	ISO VG #150
허용 하중 ALLOWABLE MASS OF WORK	100 kg [VER.]

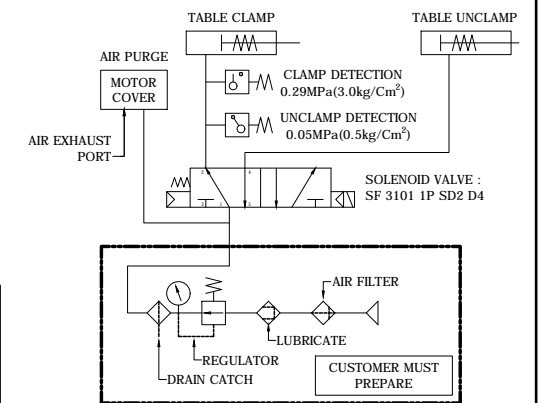

TITLE	Nc Rotary Table	PART NAME	외형도
DRG. NO.	RF-200F4	USER	-
CODE NO.	-	DEPARTMENT	Research & Development
		DATE	2020.09.01
SCALE	1 : 1		
	Approved	Checked	Designed



변경 사항			
기호	변경 내용	날짜	수정 승인

Horizontal (수평형) Type

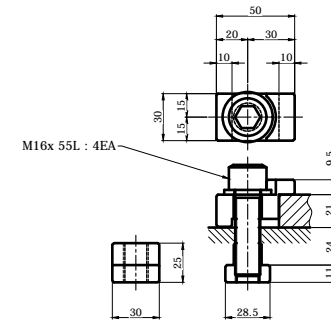
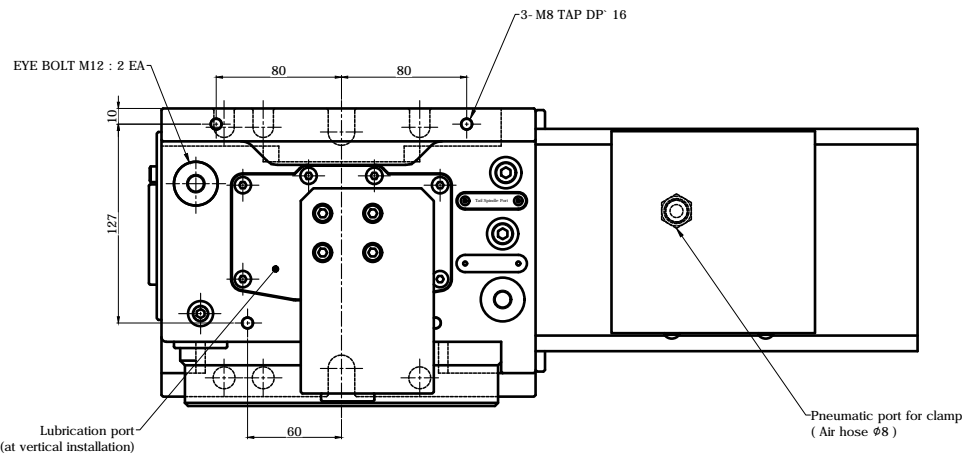
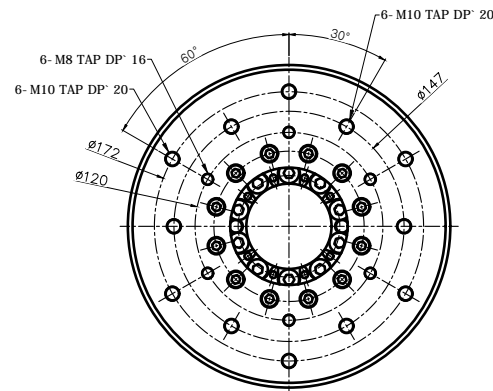

CLAMPING PARTS ACCESSORY 4 PAIR

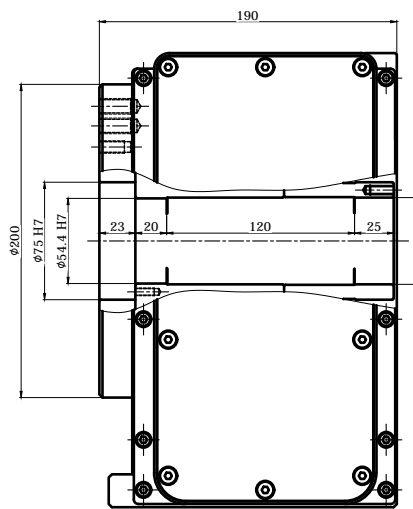
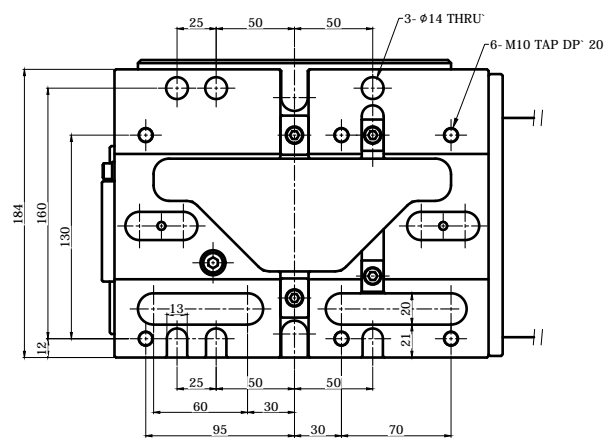
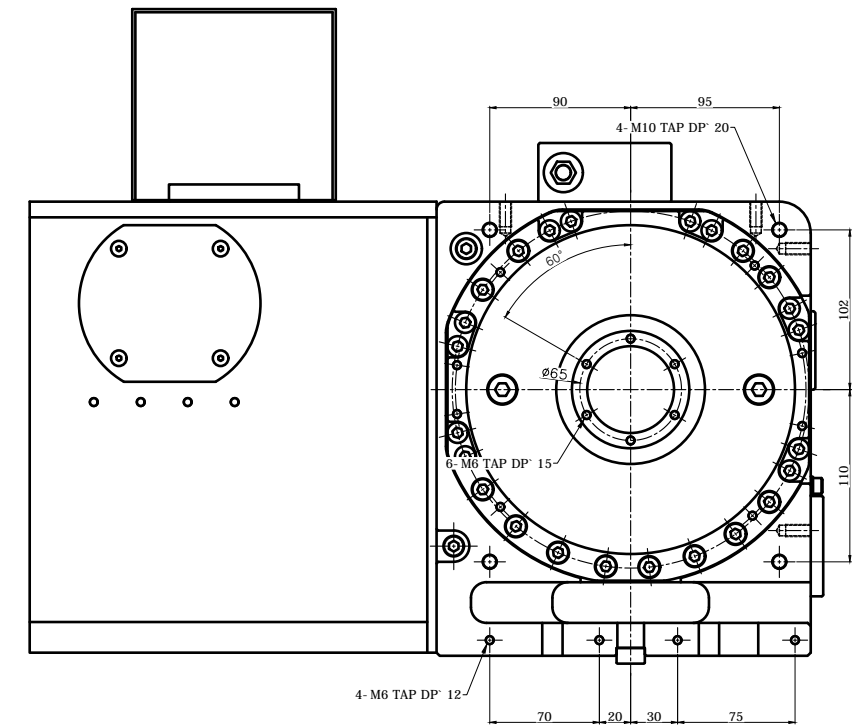
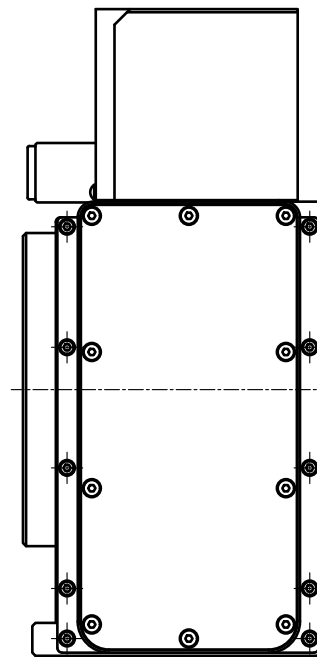
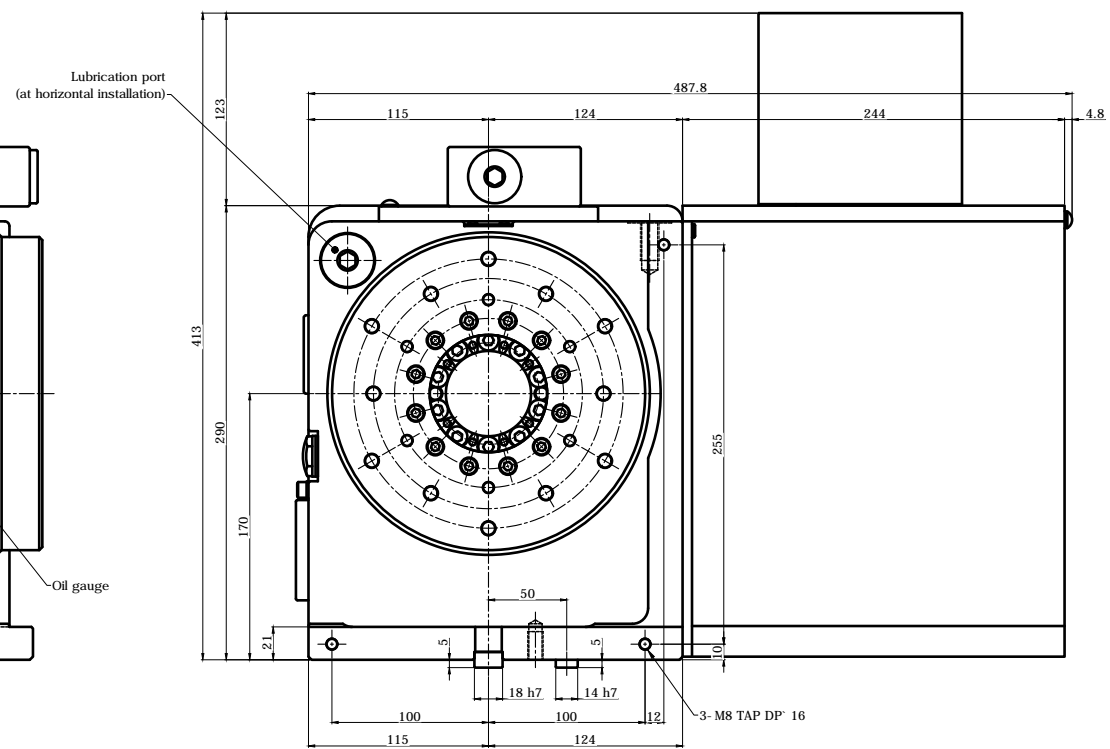
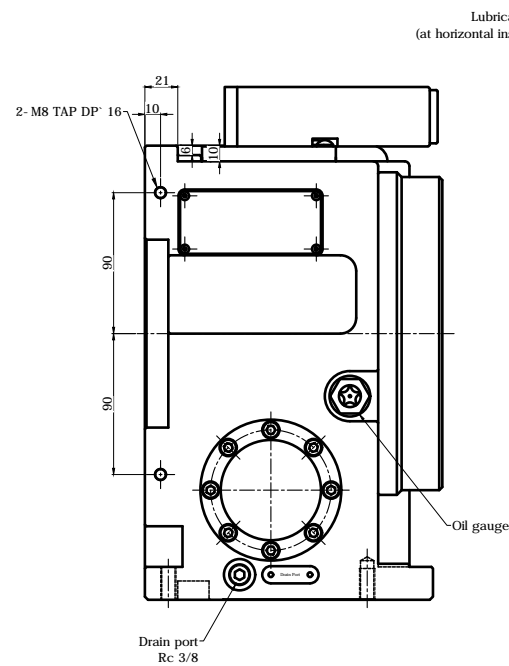
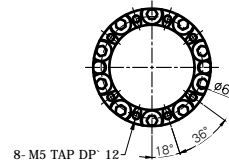

SPECIFICATION	
테이블 직경 Table Diameter	φ200 mm
센터 높이 Center Height	170 mm
테이블 내경 Table Inner Diameter	φ75 H7
스핀들 직경 Spindle Through Hole Diameter	
클램프 방식 Clamp Method	Pneumatic 5 ~ 7 kgf/cm ²
허용 모멘트 Allowable Work Inertia	0.5 kg·m ²
클램프 토크 Clamp Torque	310 N·m
최대 회전 속도 Max. Spindle Speed	50 min ⁻¹ (INVERTER WITH 2000 rpm ⁻¹)
기어비 Gear Ratio	1 / 50
무게 Weight	82 kg
기어 오일 Gear Lubrication	ISO VG #150
허용 하중 ALLOWABLE MASS OF WORK	200 kg [HOR.]

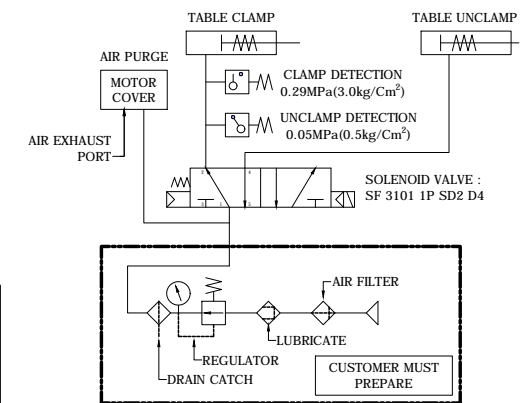

TITLE	Nc Rotary Table	PART NAME	외형도
DRG. NO.	RF-200F4 - Horizontal	USER	-
CODE NO.		DEPARTMENT	Research & Development
		DATE	2020.09.01
SCALE	1 : 1		
	Approved	Checked	Designed

